

## Using C30 Compiler and the SPI Module to Interface EEPROMs with dsPIC33F and PIC24F

*Author: Martin Kvasnicka  
Microchip Technology Inc.*

### INTRODUCTION

The 25XXX series serial EEPROMs from Microchip Technology are SPI compatible and have maximum clock frequencies ranging from 3 MHz to 20 MHz. The SPI module available on dsPIC33F Digital Signal Controller and PIC24F microcontroller provide a very easy-to-use interface for communicating with the 25XXX series devices. The largest benefit of using the SPI module is that the signal timings are handled through hardware rather than software. This allows the firmware to continue executing while communication is handled in the background. This also means that an understanding of the timing specifications associated with the SPI protocol is not required in order to use the 25XXX series devices in designs.

This application note is intended to serve as a reference for communicating with Microchip's 25XXX series serial EEPROM devices with the use of the SPI module featured on many dsPIC33F and PIC24F family devices. Source code for common data transfer modes is also provided.

Figure 1 describes the hardware schematic for the interface between Microchip's 25XXX series MCU and the dsPIC33F DSC or the PIC24F MCU. The schematic shows the connections necessary between either controller and the serial EEPROM as tested, and the software was written assuming these connections. The  $\overline{WP}$  pin is tied to Vcc because the STATUS register write-protect feature is not used in the examples provided.

**FIGURE 1: CIRCUIT FOR dsPIC33FJ256GP710, PIC24FJ128GA010 AND 25XXX SERIES DEVICE**

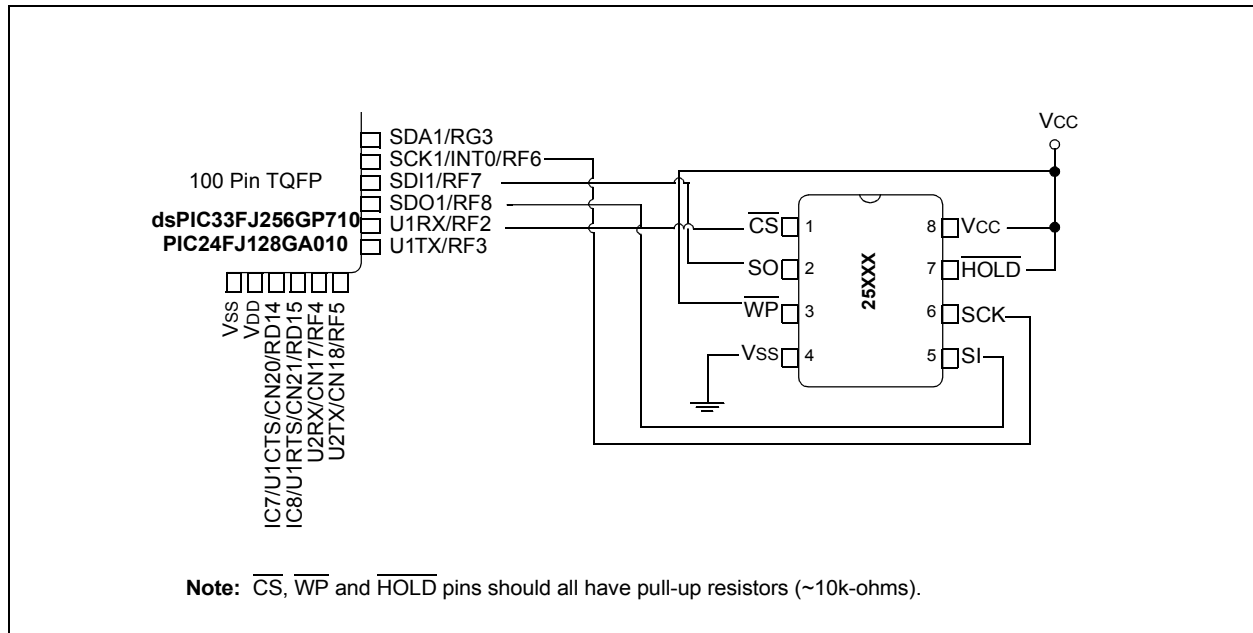

# AN1069

---

## FIRMWARE DESCRIPTION

The purpose of the program is to show individual features of the SPI protocol and give code samples of the opcodes so that the basic building blocks of a program can be shown. The firmware was written in C and the Microchip C30 compiler was used. The opcodes used in the program are Write Enable (WREN), Write, Read, and Read Status Register (RDSR) (used in the program for WIP polling). The oscilloscope pictures have markers that are shown from  $\overline{CS}$  enable to  $\overline{CS}$  disable for ease in reading. The data sheet version of the waveform is below the actual oscilloscope picture. The SPI module is set up for Mode 0,0 operation. The code is written in modules and commented so changing modes, speeds, and modifying commands such as sequential reads and page writes is simple. The values represented in this application note are all hex values unless otherwise noted.

Besides the standard SPI libraries supplied with the C30 compiler, the firmware consists of two .c files (AN1069.c and AN1069\_spi.c), organized into nine sections.

- Initialization
- Low Density Byte Write
- Low Density Byte Read
- Low Density Page Write
- Low Density Page Read
- High Density Byte Write
- High Density Byte Read
- High Density Page Write
- High Density Page Read

The low density routines are intended for use with the 4K and smaller density devices that use only one byte of address (25XX010A, 25XX020A, and 25XX040A) 1, 2, and 4 Kbit devices. The Most Significant bit (A8) for the 25XX040A device resides in the control code, please refer to the individual data sheet for particulars. The high density routines are intended for use with 8 Kbit and higher density devices that use two bytes of address. This program also exhibits the WIP polling feature for detecting the completion of write cycles after the byte write and page write operations. Read operations are located directly after each write operation, thus allowing for verification that the data was properly written. No method of displaying the input data is provided, but a SEEVAL<sup>®</sup> 32 evaluation system, an oscilloscope, or a Microchip MPLAB<sup>®</sup> ICD 2 could be used.

The code was tested using a 25LC256 serial EEPROM. This device features 32k x 8 (256 Kbit) of memory and 64-byte pages.

## INITIALIZATION

In order to configure the SPI module for SPI mode 0,0, several key registers on the dsPIC33F DSC or PIC24F MCU need to be properly initialized.

### SPI1STAT STATUS Register (SPI1STAT)

SPI1STAT holds all of the Status bits associated with the SPI module. The SPI Enable bit (SPIPEN) must be set in order to enable the serial port.

### SPI1 Control Register (SPI1CON1)

SPI1CON1 is one of the Configuration registers for the SPI module. In SPI mode 0,0, the SMP bit of the register needs to be set for data to be sampled at the end of the output time. The Clock Polarity Select bit (CKP) needs to be cleared for Idle state of the clock to be a low level. The MSTEN bit needs to be set for "Master" mode. Finally, the Secondary Prescale bits (SPRE) and the Primary Prescale bits (PPRE) are configured, in this case, 2:1 (Secondary) and 1:1 (Primary). SPI1CON2 is used for "framed" SPI support, is not used in the code here and, therefore, is cleared during initialization.

## TRISF Register

In order to be properly controlled the  $\overline{CS}$  pin must be configured as an output. This is done by setting the respective bit in TRISF to '0' for output. The SCK, SDI and SDO pins will automatically be configured when the SPI Enable bit is set.

# AN1069

## WRITE ENABLE

Figure 2 shows an example of the Write Enable command. Chip Select is brought low (active) and the opcode is sent out through the SPI port. The Write Enable command must be given before a write is attempted to either the array or the STATUS register. The WEL bit can be cleared by issuing a Write Disable command (WRDI) or it is automatically reset if the device is powered down or a write cycle is completed.

**FIGURE 2: WRITE ENABLE (WREN)**

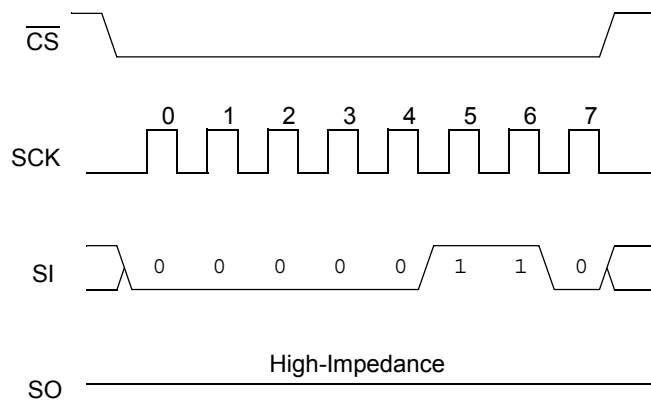
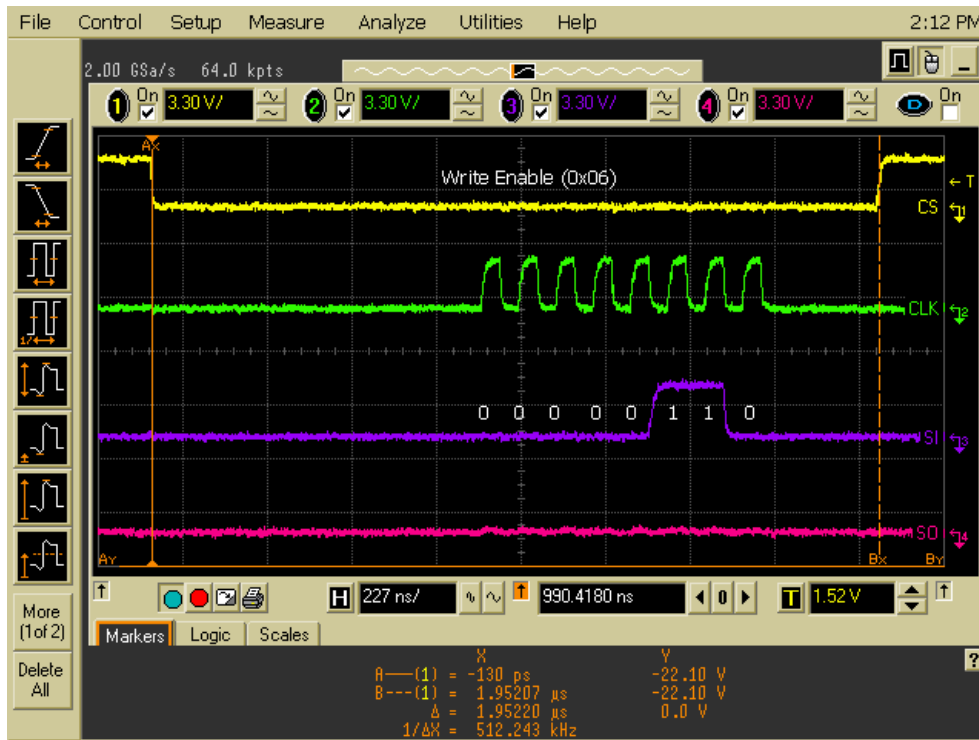

## READ STATUS REGISTER TO CHECK FOR WEL BIT

Figure 3 shows an example of the Read Status Register command to check for the WEL bit. The WEL bit must be set before a write is attempted to either the STATUS register or the array. It is good programming practice to check whether this bit is set before attempting the write.

Once again the device is selected and the opcode, 0x05, is sent. The STATUS register is shifted out on the Serial Out pin. A value of 0x02 shows that the WEL bit in the STATUS register has been set. The device is now ready to do a write to either the STATUS register or the array.

**FIGURE 3: READ STATUS REGISTER TO CHECK FOR WEL BIT (RDSR)**

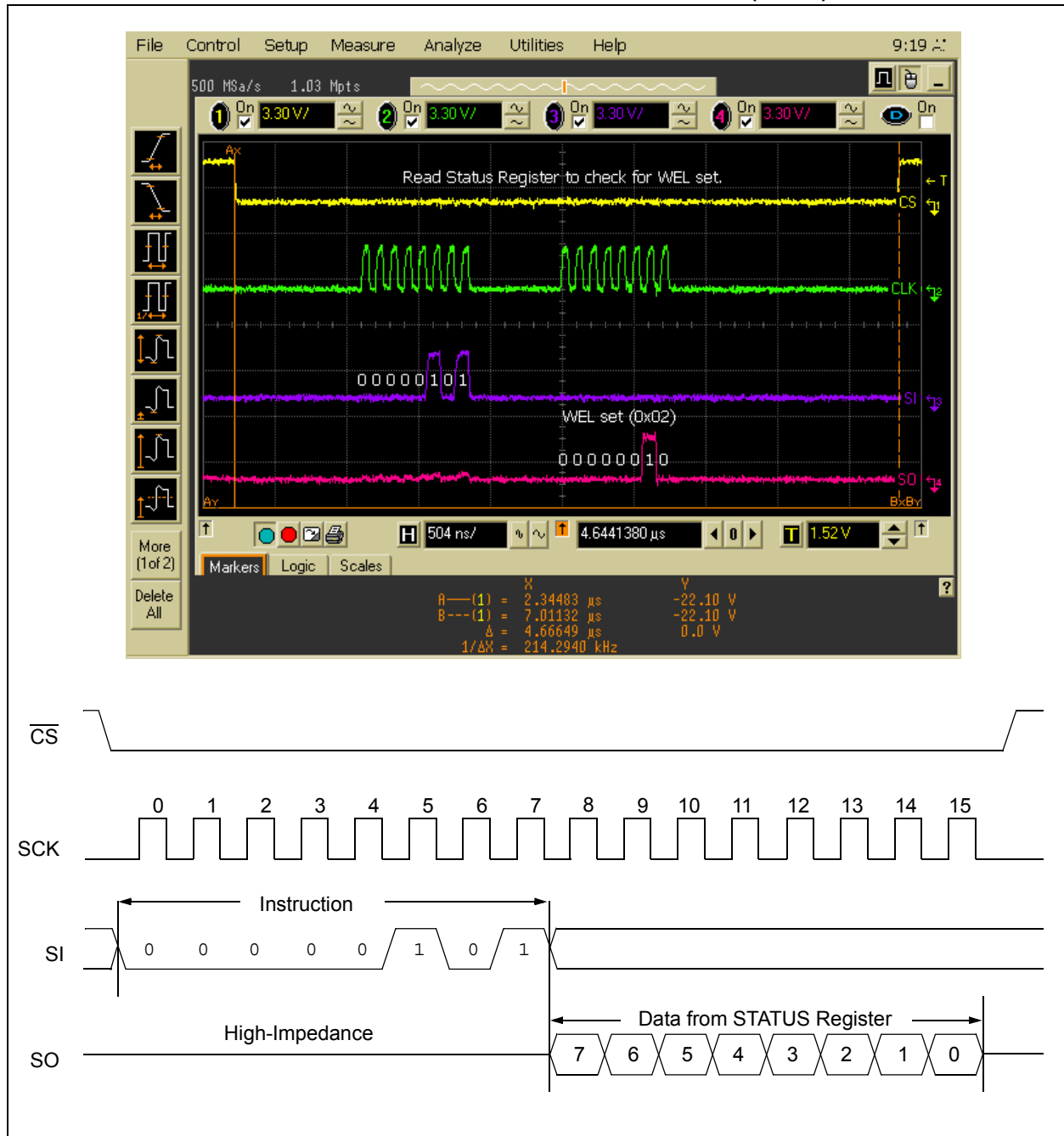

# AN1069

## BYTE WRITE COMMAND (OPCODE, ADDRESS AND DATA)

Figure 4 shows an example of the Write command. For this, the device is selected and the opcode, 0x02, is sent. The High Address byte is given 0x00, followed by the Low Address byte, 0x10. Finally, the data is clocked in last, in this case, 0xA5. Once the Chip Select is toggled at the end of this command, the internal write cycle is initiated. Once the internal write cycle has begun, the WIP bit in the STATUS register can now be polled to check when the write finishes or a delay needs to be added (~5ms), if the WIP bit is not being polled. This code uses WIP polling.

A page write can be accomplished by continuing to give data bytes to the device without toggling  $\overline{CS}$ . Up to one full page (64 bytes for the 25XX256) can be written before a write cycle is needed. Once  $\overline{CS}$  is brought high after the data bytes have been transmitted, then the write cycle timer will begin and normal polling can be initiated. The included page write function programs all 64 bytes of data in the first page. Since the starting address is 0x0010, the last 16 bytes of data will wrap from address 0x003F to address 0x0000 and complete the page. Caution should be taken when initiating writes in this manner so that previously stored data doesn't get overwritten.

**FIGURE 4: BYTE WRITE COMMAND, ADDRESS AND DATA**

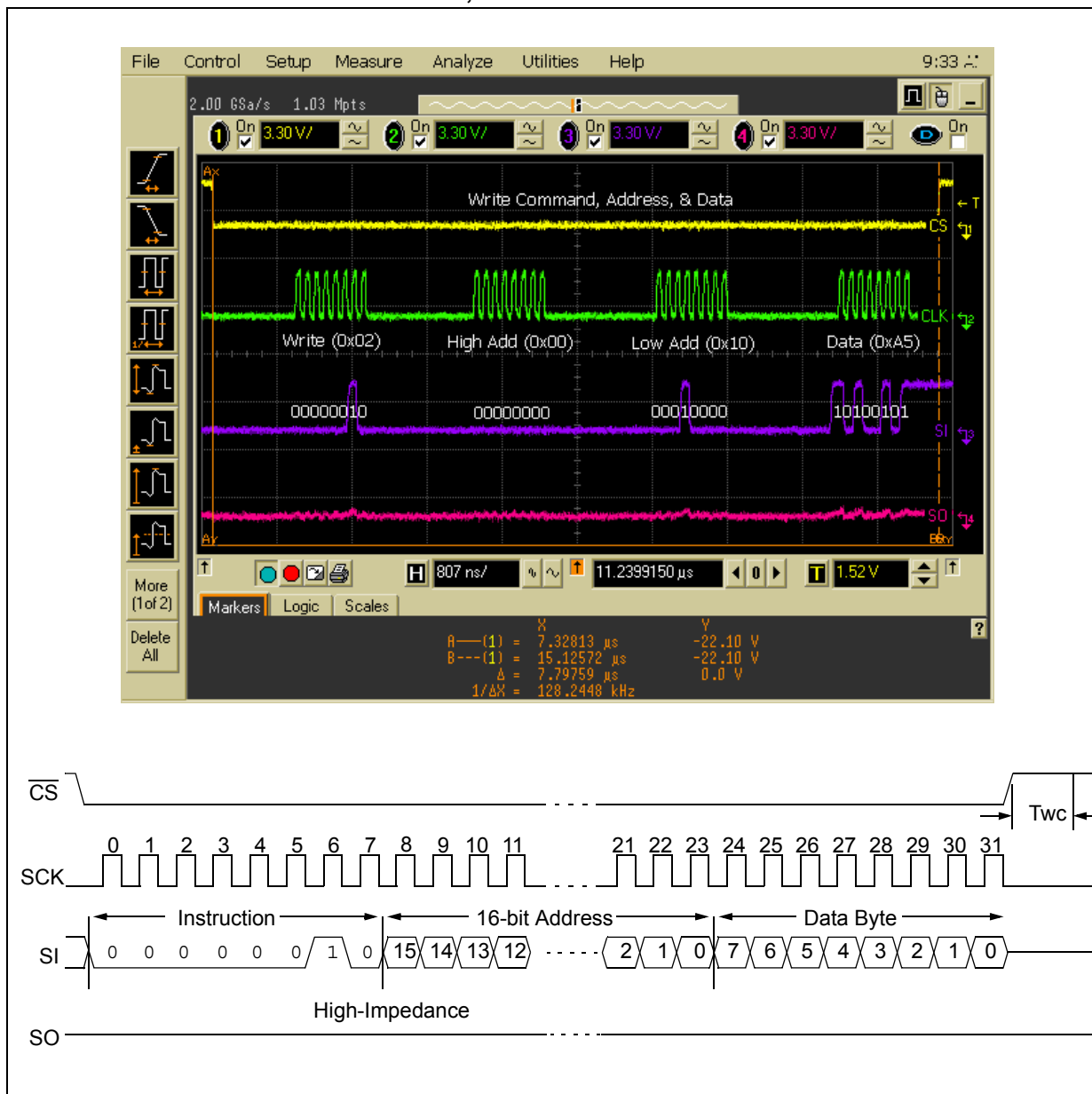

## DATA POLLING (RDSR – CHECK FOR WIP SET)

After a valid Write command is given, the STATUS register can be read to check if the internal write cycle has been initiated, and it can continuously be monitored to look for the end of the write cycle. In this case, the device is selected and the opcode, 0x05, is sent. The STATUS register is then shifted out on the Data Out pin, resulting in a value of 0x03. Figure 5 shows that both the WEL bit (bit 1) and the WIP bit (bit 0) are set, meaning the write cycle is in progress.

**FIGURE 5: DATA POLLING (READ STATUS REGISTER TO CHECK WIP BIT)**

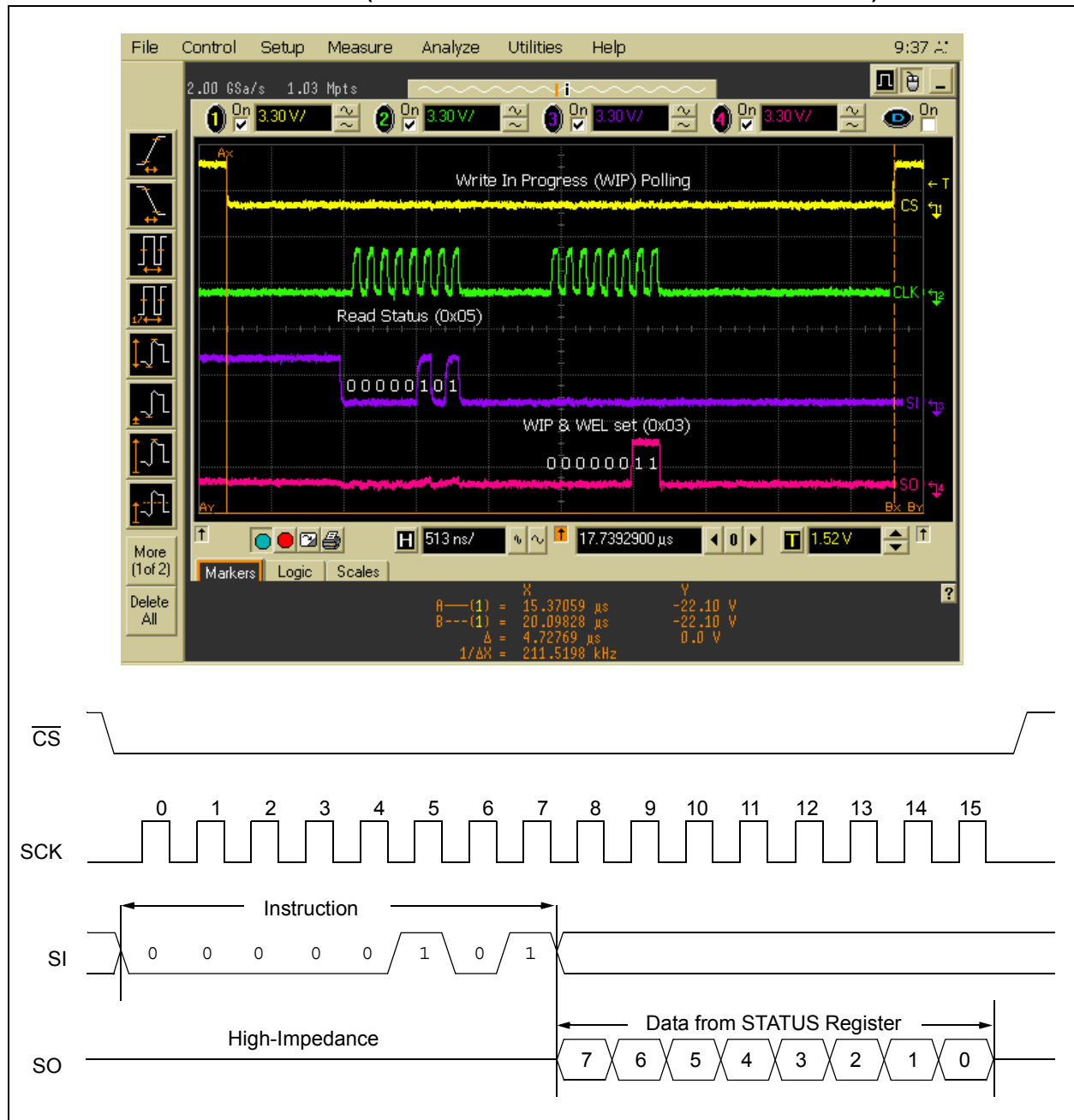

# AN1069

## DATA POLLING FINISHED (RDSR – WIP BIT CLEARED)

The part remains in a continuous RDSR loop and the WIP status is evaluated until the bit is cleared. Figure 6 shows the Status Register Read command followed by a value of 0x00 being shifted out on the Data Out pin.

This indicates that the write cycle has finished and the device is now ready for additional commands. The WEL bit is also cleared at the end of a write cycle, which serves as additional protection against unwanted writes.

**FIGURE 6: DATA POLLING FINISHED (RDSR – WIP AND WEL BITS CLEARED)**

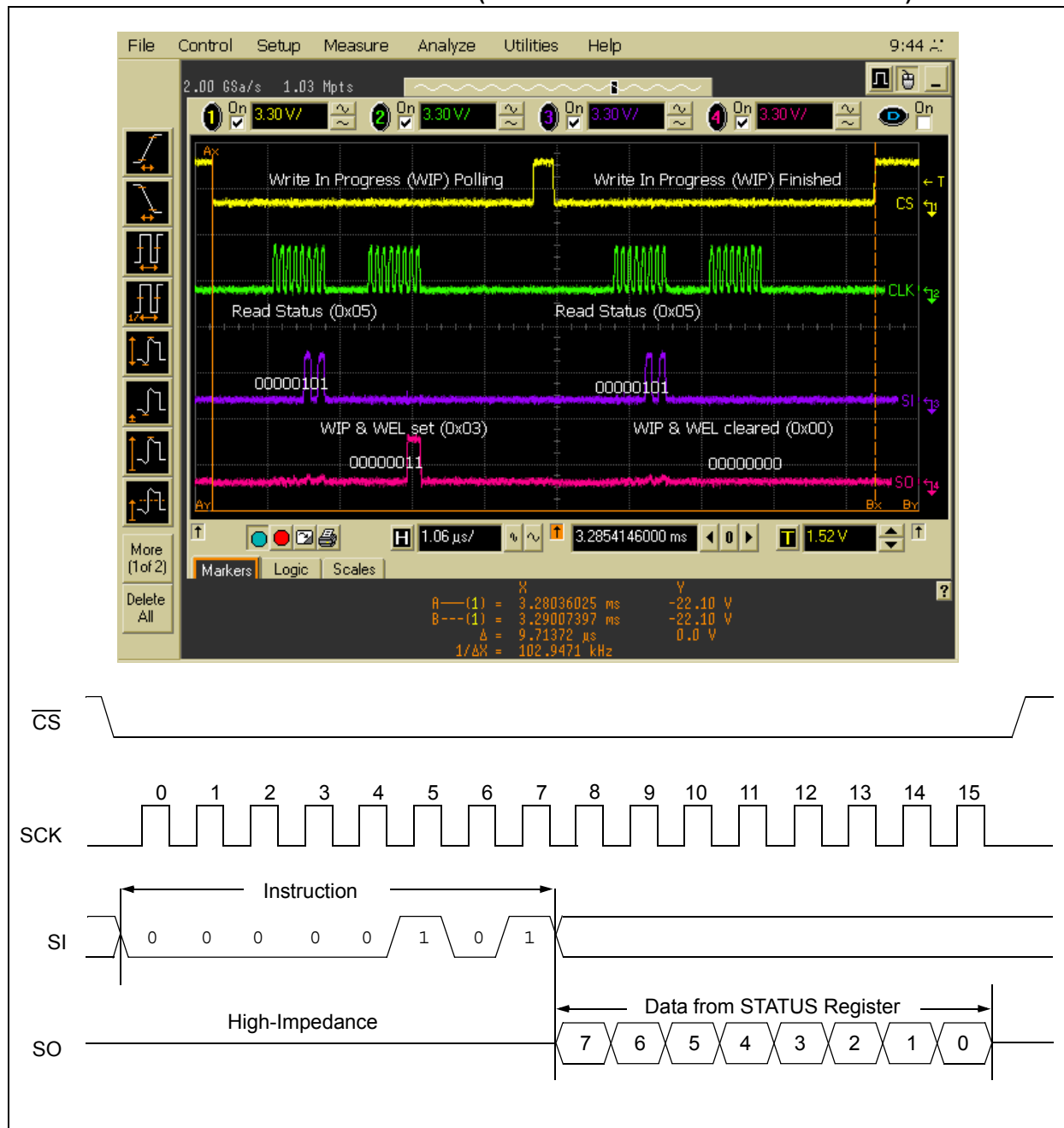



## READ COMMAND (OPCODE, ADDRESS AND DATA)

Figure 7 shows an example of the Read command. For this, the device is selected and the opcode, 0x03, is sent. The High Address byte is given 0x00, followed by the Low Address byte, 0x10. Finally, the data is clocked

out on the Serial Out pin, in this case, 0xA5. In order to do a sequential read, more clocks need to be generated. It is possible to read the entire chip by continuing to provide clocks to the device. Once the end of the array is reached, the data will wrap to the beginning of the array (Address 0x0000) and keep reading out until  $\overline{\text{CS}}$  is deselected or clocks stop being provided.

**FIGURE 7: READ COMMAND, ADDRESS AND DATA**

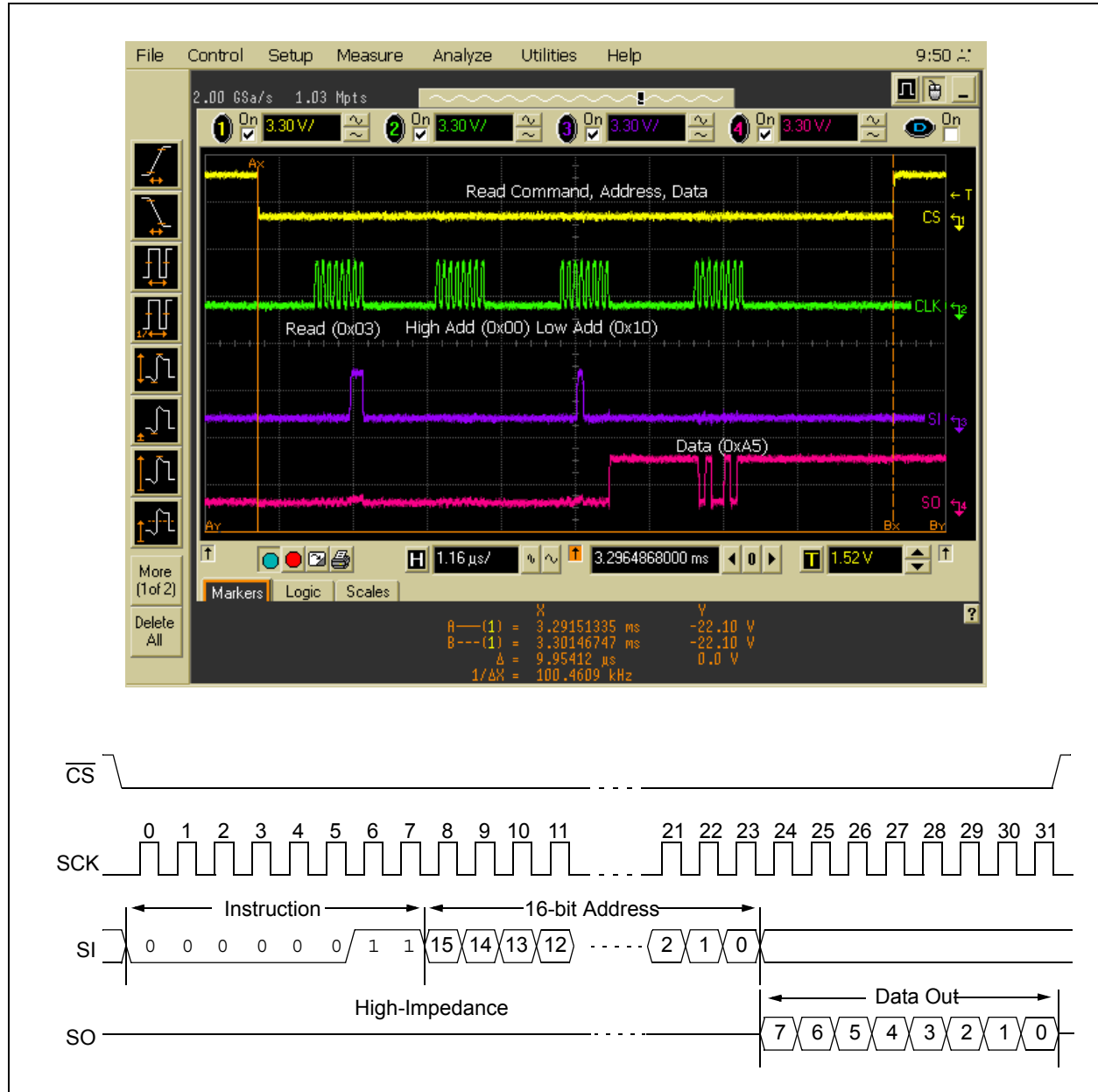

## CHANGING PROCESSORS

This application note code was written to simplify changing between processors. There are, however, a couple of steps that need to be taken in order to do this. This application note was tested with two specific processors, the dsPIC33FJ256GP710 and the PIC24FJ128GA010. If you are going to use processors that are different from these two, please consult the device-specific data sheet to check for any other potential issues when using this code. As mentioned previously, the Explorer 16 development board was used for this application note with the connections shown in Figure 1. In order to change between these processors there are four steps:

1. The current processor module currently on the Explorer 16 board must be physically replaced with the processor module desired. Be sure to disconnect power during this procedure.
2. The #define statements on lines 30 and 31 in the an1096.h file must be commented in/out for the desired processor.
3. The new processor needs to be selected in the MPLAB<sup>®</sup> IDE by going to Configure>Select Device...
4. The linker file needs to be added/removed for the desired processor. If this is not done, it will not prevent the code from compiling but will remove some undesired warnings from the compiler.

## CONCLUSION

These are some of the basic features of SPI communications using the SPI module on one of Microchip's dsPIC33F devices. The code is highly portable and can be used on many devices that have the SPI module with very minor modifications. Using the code provided, designers can begin to build their own SPI libraries to be as simple or complex as needed. The code was tested on Microchip's Explorer 16 Development Board with the connections shown in Figure 1.

---

---

**Note the following details of the code protection feature on Microchip devices:**

- Microchip products meet the specification contained in their particular Microchip Data Sheet.
- Microchip believes that its family of products is one of the most secure families of its kind on the market today, when used in the intended manner and under normal conditions.
- There are dishonest and possibly illegal methods used to breach the code protection feature. All of these methods, to our knowledge, require using the Microchip products in a manner outside the operating specifications contained in Microchip's Data Sheets. Most likely, the person doing so is engaged in theft of intellectual property.
- Microchip is willing to work with the customer who is concerned about the integrity of their code.
- Neither Microchip nor any other semiconductor manufacturer can guarantee the security of their code. Code protection does not mean that we are guaranteeing the product as "unbreakable."

Code protection is constantly evolving. We at Microchip are committed to continuously improving the code protection features of our products. Attempts to break Microchip's code protection feature may be a violation of the Digital Millennium Copyright Act. If such acts allow unauthorized access to your software or other copyrighted work, you may have a right to sue for relief under that Act.

---

Information contained in this publication regarding device applications and the like is provided only for your convenience and may be superseded by updates. It is your responsibility to ensure that your application meets with your specifications. MICROCHIP MAKES NO REPRESENTATIONS OR WARRANTIES OF ANY KIND WHETHER EXPRESS OR IMPLIED, WRITTEN OR ORAL, STATUTORY OR OTHERWISE, RELATED TO THE INFORMATION, INCLUDING BUT NOT LIMITED TO ITS CONDITION, QUALITY, PERFORMANCE, MERCHANTABILITY OR FITNESS FOR PURPOSE. Microchip disclaims all liability arising from this information and its use. Use of Microchip devices in life support and/or safety applications is entirely at the buyer's risk, and the buyer agrees to defend, indemnify and hold harmless Microchip from any and all damages, claims, suits, or expenses resulting from such use. No licenses are conveyed, implicitly or otherwise, under any Microchip intellectual property rights.

**Trademarks**

The Microchip name and logo, the Microchip logo, Accuron, dsPIC, KEELOQ, KEELOQ logo, microID, MPLAB, PIC, PICmicro, PICSTART, PRO MATE, rPIC and SmartShunt are registered trademarks of Microchip Technology Incorporated in the U.S.A. and other countries.

AmpLab, FilterLab, Linear Active Thermistor, Migratable Memory, MXDEV, MXLAB, SEEVAL, SmartSensor and The Embedded Control Solutions Company are registered trademarks of Microchip Technology Incorporated in the U.S.A.

Analog-for-the-Digital Age, Application Maestro, CodeGuard, dsPICDEM, dsPICDEM.net, dsPICworks, dsSPEAK, ECAN, ECONOMONITOR, FanSense, FlexROM, fuzzyLAB, In-Circuit Serial Programming, ICSP, ICEPIC, Mindi, MiWi, MPASM, MPLAB Certified logo, MPLIB, MPLINK, PICkit, PICDEM, PICDEM.net, PICLAB, PICtail, PowerCal, PowerInfo, PowerMate, PowerTool, REAL ICE, rLAB, Select Mode, Smart Serial, SmartTel, Total Endurance, UNI/O, WiperLock and ZENA are trademarks of Microchip Technology Incorporated in the U.S.A. and other countries.

SQTP is a service mark of Microchip Technology Incorporated in the U.S.A.

All other trademarks mentioned herein are property of their respective companies.

© 2007, Microchip Technology Incorporated, Printed in the U.S.A., All Rights Reserved.

 Printed on recycled paper.

**QUALITY MANAGEMENT SYSTEM  
CERTIFIED BY DNV  
== ISO/TS 16949:2002 ==**

*Microchip received ISO/TS-16949:2002 certification for its worldwide headquarters, design and wafer fabrication facilities in Chandler and Tempe, Arizona; Gresham, Oregon and design centers in California and India. The Company's quality system processes and procedures are for its PIC® MCUs and dsPIC® DSCs, KEELOQ® code hopping devices, Serial EEPROMs, microperipherals, nonvolatile memory and analog products. In addition, Microchip's quality system for the design and manufacture of development systems is ISO 9001:2000 certified.*



---

---

## WORLDWIDE SALES AND SERVICE

---

---

### AMERICAS

**Corporate Office**  
2355 West Chandler Blvd.  
Chandler, AZ 85224-6199  
Tel: 480-792-7200  
Fax: 480-792-7277  
Technical Support:  
<http://support.microchip.com>  
Web Address:  
[www.microchip.com](http://www.microchip.com)

#### Atlanta

Duluth, GA  
Tel: 678-957-9614  
Fax: 678-957-1455

#### Boston

Westborough, MA  
Tel: 774-760-0087  
Fax: 774-760-0088

#### Chicago

Itasca, IL  
Tel: 630-285-0071  
Fax: 630-285-0075

#### Dallas

Addison, TX  
Tel: 972-818-7423  
Fax: 972-818-2924

#### Detroit

Farmington Hills, MI  
Tel: 248-538-2250  
Fax: 248-538-2260

#### Kokomo

Kokomo, IN  
Tel: 765-864-8360  
Fax: 765-864-8387

#### Los Angeles

Mission Viejo, CA  
Tel: 949-462-9523  
Fax: 949-462-9608

#### Santa Clara

Santa Clara, CA  
Tel: 408-961-6444  
Fax: 408-961-6445

#### Toronto

Mississauga, Ontario,  
Canada  
Tel: 905-673-0699  
Fax: 905-673-6509

### ASIA/PACIFIC

**Asia Pacific Office**  
Suites 3707-14, 37th Floor  
Tower 6, The Gateway  
Harbour City, Kowloon  
Hong Kong  
Tel: 852-2401-1200  
Fax: 852-2401-3431

**Australia - Sydney**  
Tel: 61-2-9868-6733  
Fax: 61-2-9868-6755

**China - Beijing**  
Tel: 86-10-8528-2100  
Fax: 86-10-8528-2104

**China - Chengdu**  
Tel: 86-28-8665-5511  
Fax: 86-28-8665-7889

**China - Fuzhou**  
Tel: 86-591-8750-3506  
Fax: 86-591-8750-3521

**China - Hong Kong SAR**  
Tel: 852-2401-1200  
Fax: 852-2401-3431

**China - Nanjing**  
Tel: 86-25-8473-2460  
Fax: 86-25-8473-2470

**China - Qingdao**  
Tel: 86-532-8502-7355  
Fax: 86-532-8502-7205

**China - Shanghai**  
Tel: 86-21-5407-5533  
Fax: 86-21-5407-5066

**China - Shenyang**  
Tel: 86-24-2334-2829  
Fax: 86-24-2334-2393

**China - Shenzhen**  
Tel: 86-755-8203-2660  
Fax: 86-755-8203-1760

**China - Shunde**  
Tel: 86-757-2839-5507  
Fax: 86-757-2839-5571

**China - Wuhan**  
Tel: 86-27-5980-5300  
Fax: 86-27-5980-5118

**China - Xian**  
Tel: 86-29-8833-7252  
Fax: 86-29-8833-7256

### ASIA/PACIFIC

**India - Bangalore**  
Tel: 91-80-4182-8400  
Fax: 91-80-4182-8422

**India - New Delhi**  
Tel: 91-11-4160-8631  
Fax: 91-11-4160-8632

**India - Pune**  
Tel: 91-20-2566-1512  
Fax: 91-20-2566-1513

**Japan - Yokohama**  
Tel: 81-45-471- 6166  
Fax: 81-45-471-6122

**Korea - Daegu**  
Tel: 82-53-744-4301  
Fax: 82-53-744-4302

**Korea - Seoul**  
Tel: 82-2-554-7200  
Fax: 82-2-558-5932 or  
82-2-558-5934

**Malaysia - Kuala Lumpur**  
Tel: 60-3-6201-9857  
Fax: 60-3-6201-9859

**Malaysia - Penang**  
Tel: 60-4-227-8870  
Fax: 60-4-227-4068

**Philippines - Manila**  
Tel: 63-2-634-9065  
Fax: 63-2-634-9069

**Singapore**  
Tel: 65-6334-8870  
Fax: 65-6334-8850

**Taiwan - Hsin Chu**  
Tel: 886-3-572-9526  
Fax: 886-3-572-6459

**Taiwan - Kaohsiung**  
Tel: 886-7-536-4818  
Fax: 886-7-536-4803

**Taiwan - Taipei**  
Tel: 886-2-2500-6610  
Fax: 886-2-2508-0102

**Thailand - Bangkok**  
Tel: 66-2-694-1351  
Fax: 66-2-694-1350

### EUROPE

**Austria - Wels**  
Tel: 43-7242-2244-39  
Fax: 43-7242-2244-393

**Denmark - Copenhagen**  
Tel: 45-4450-2828  
Fax: 45-4485-2829

**France - Paris**  
Tel: 33-1-69-53-63-20  
Fax: 33-1-69-30-90-79

**Germany - Munich**  
Tel: 49-89-627-144-0  
Fax: 49-89-627-144-44

**Italy - Milan**  
Tel: 39-0331-742611  
Fax: 39-0331-466781

**Netherlands - Drunen**  
Tel: 31-416-690399  
Fax: 31-416-690340

**Spain - Madrid**  
Tel: 34-91-708-08-90  
Fax: 34-91-708-08-91

**UK - Wokingham**  
Tel: 44-118-921-5869  
Fax: 44-118-921-5820

10/05/07