

DS90C031,DS90LV027

*Application Note 1088 LVDS Signal Quality: Cable Drive Measurements using
Eye Patterns Test Report #3*



Literature Number: SNLA004

LVDS Signal Quality: Cable Drive Measurements using Eye Patterns Test Report #3

National Semiconductor
Application Note 1088
July 1998



HOW FAST? AND HOW FAR?

The above two questions should be asked together because they are related to one another. Each one is a critical part of the complete system. (See *Figure 1*). The first question concerns the physical layer integrated circuits (ICs) referred to as drivers and receivers. The second question concerns the media interface between the driver(s) and receiver(s). Each question deserves its own application note to specify the particulars of issues associated with its section of the system. However, it is not enough to understand each part of the system, but understanding the relationship between the respective parts of the system is very important. This report is concerned with the relationship between the two questions which include measurement techniques, trade-offs, typical characteristic curves, and recommendations based on empirical data from LVDS drivers and receivers.

MEASUREMENTS

Before beginning measurements, some decisions are made about the test conditions and the environment. Obviously, the ideal setup would be to take the measurements on the actual system application. In this case, a general setup is used since this data is for general use. (See *Figure 5*.) For the same reason, room temperature, nominal power supply, and general off-the-shelf equipment are used for the experiment. Further experiment details will follow but now, one out of several measurement techniques must be selected. For example, Bit Error Rate Testing (BERT), eye pattern testing, and slew rate evaluation are some of the different ways to evaluate system performance. There are reasons why one

option may be chosen over another, but it is typically application dependent. Type of equipment available, application criteria, transmitting scheme, and receiving scheme all play a part in the decision process. Eye pattern testing was selected for this report for equipment and previous data comparison reasons.

WHY EYE PATTERNS?

Eye pattern measurements may be used to measure the amount of jitter versus the unit interval (bit width) to establish the data rate versus cable length curves and therefore is a very accurate way to measure the expected signal quality in the end application and furthermore addresses the concerns of this report. The eye pattern may be used to measure the effects of inter-symbol interference (ISI) of random data being transmitted through a particular media. The transition time of the signal is effected by the prior data bits, this is especially true for Non-Return to Zero (NRZ) data which does not guarantee periodic transitions on the line. For example in NRZ coding, a transition high after a long series of lows has a slower rise time than the rise time of a periodic (010101) waveform. This is due to the low pass filter effects of the cable. *Figure 2* illustrates the superposition of six different data patterns. Overlaid they form the eye pattern that is the input to the cable. The right hand side of *Figure 2* illustrates the same pattern at the end of the cable. Note the rounding of the formerly sharp transitions. The width of the crossing point is now wider, and the opening of the eye is also now smaller (see AN-808 for an extensive discussions on eye patterns).

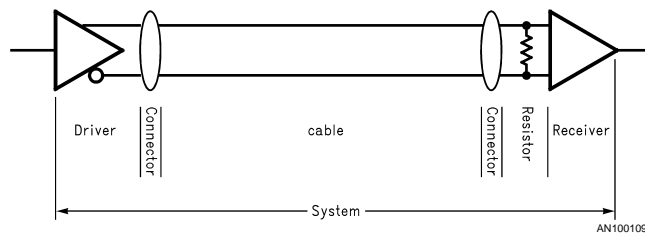

FIGURE 1. Typical Interface System Components

Additionally, whenever the system is used to supply both clock and data, using NRZ coding, and the clock frequency equals the data rate ($\text{clk_Hz} = \text{data_bps}$); then the period of the clock, not the unit interval of the clock, should be used to determine the maximum cable length. Although the clock's

unit interval (UI) is half the data's UI, the same maximum cable length limit for data also apply to the clock. This is due to the fact that the clock's periodic waveform is not prone to distortion from inter symbol distortion as is a data line.

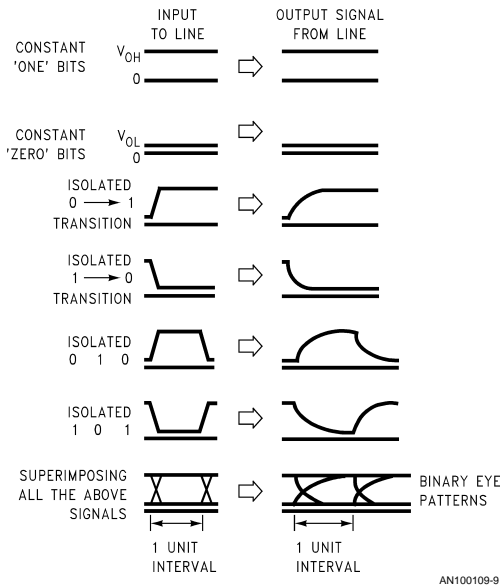

FIGURE 2. Formation of an Eye Pattern by Superposition

Figure 3 shows the measurement locations for jitter. Peak-to-Peak Jitter is the width of the signal crossing the optimal receiver threshold level. For a differential receiver, that would correspond to zero Volts (differential).

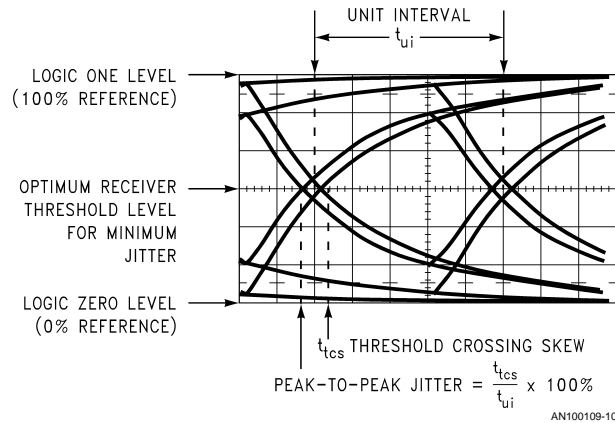

FIGURE 3. NRZ Data Eye Pattern

TEST MEASUREMENT SETUP

The test setup used is a general setup since the data acquired from it is for general purpose use. The equivalent PC board configuration is shown in Figure 4. However, the actual test board has components not shown, like jumpers for

IC configurations, by-pass capacitors, and additional SMB connectors for waveform monitoring purposes. The PCB along with the equipment listed in Table 1 were all used in the experiment setup. The complete test set up is shown in Figure 5.

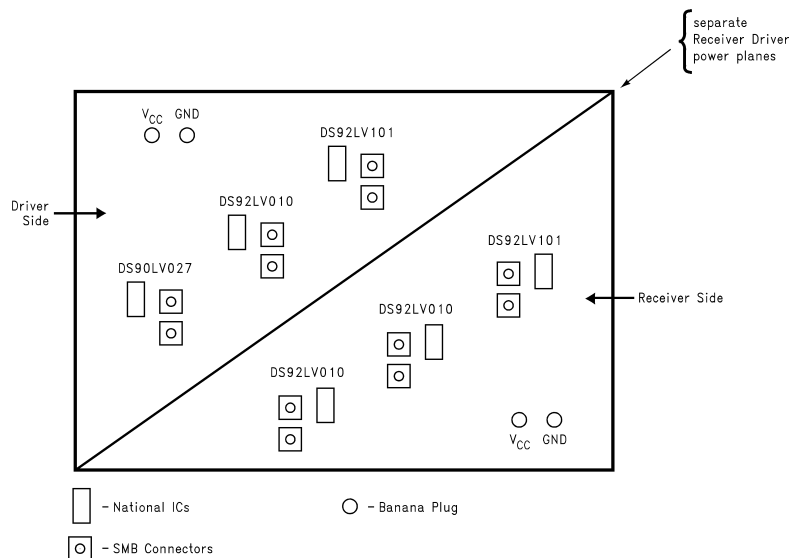

FIGURE 4. Equivalent PCB for Test Measurement Setup

AN100109-2

TABLE 1. Test Measurement Equipment

Equipment	Manufacturer	Model Number
Power Supply	Hewlett-Packard	6626A
Function Generator	Tektronix	HFS9009
Oscilloscope	Tektronix	11801B
Probes	Tektronix	SD-14
CAT 3 Cable	Beldon	9842

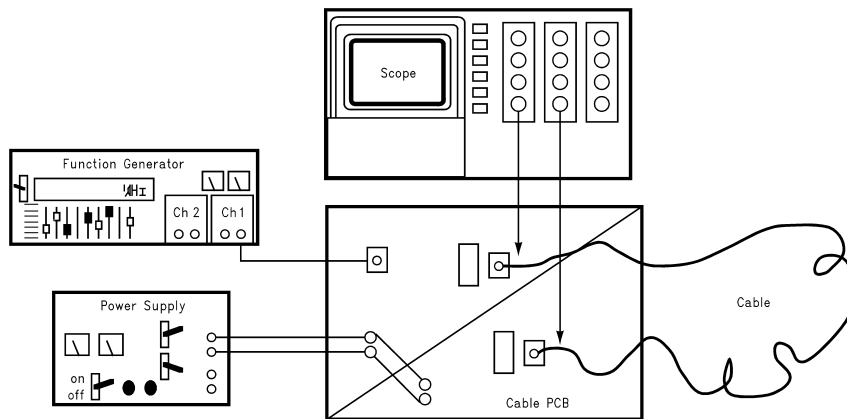

FIGURE 5. Test Equipment Setup

AN100109-3

TEST PROCEDURE

A pseudo-random bit sequence (PRBS) was programmed into the function generator and connected to the driver input via a 50Ω cable with a SMB connector. The sequence was 512 (2⁹) bits long. The length is restricted by the equipment

used. The power supply was connected to both the driver and receiver side of the PCB and grounds were tied together, therefore common mode voltage range is not being tested. The oscilloscope was used to probe the resulting eye pattern, measured differentially at both the output of the

driver and the input of the receiver. A 100Ω resistor was used to terminate the signals at the far end of the cable. Only the measurements taken at the far end of the cable, at the receiver's input, are used for the jitter analysis in this report. The frequency of the input signal was increased until the measured jitter (t_{cs}) in *Figure 3*, equaled 20% with respect to the unit interval (t_{ui}) for the particular cable length under test. The coding scheme used was NRZ. Jitter was measured at the zero volt differential voltage of the differential eye pattern. Five different cable lengths were tested (2, 10, 20, 50,

and 100 meters) to generate the curves in the data and results section of this report. Category 3 cables were tested. The CAT 3 cable was a Beldon 9842 shielded twisted pair cable. This cable is 24 gauge with tinned copper conductors and polyethylene insulation. Testing was done at room temperature and the power supply was set to 3.3V. Only LVDS style devices (DS90LV027, DS92LV101 (test device similar to DS92LV010A with separate driver and receiver), and DS92LV010A) were tested.

DATA AND RESULTS

TABLE 2. 20% Jitter Table @ 0V Differential with CAT 3

Cable Length — (meter)	Data Rate — (Mbps)	Unit Interval — tui (ns)	Jitter — tcs (ns)
2	337	2.97	0.594
10	325	3.08	0.616
20	280	3.57	0.714
50	135	7.41	1.482
100	35	28.57	5.714

Note the data in and *Table 2* is for all devices tested. The DS90LV027 is a 3 mA current source driver. The DS92LV010 is a high drive current source driver capable of delivering about 5.5 mA with a 100Ω load. No difference in the measurement was noticeable between 3 mA and 5.5 mA current drivers, as the transition times of both devices is similar. This is also a result of the measurement technique. Since jitter was measured horizontal at zero volts differential (crossing point), which does not vary too much with small current drive difference, the measurements remain constant across all devices. Examining the data in *Table 2*, shows the CAT 3 cable has good performance (above 100 Mbps with 20% jitter) to 50 meters. The data for *Table 2* is plotted in *Figure 6*. Note that the data is plotted in log vs. log scale. This is done to display the roll off point better.

will have the opposite effect on the system. Twenty percent jitter is a reasonable place to start with many system designs.

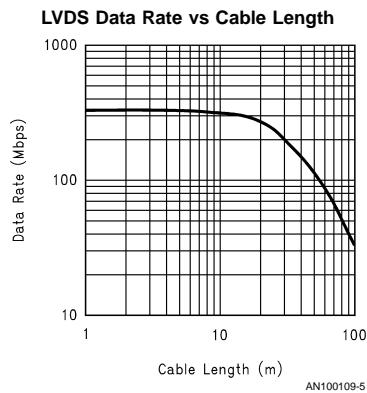

FIGURE 6. CAT 3 Cable Length vs Frequency

Figure 6 shows very good typical performance curve that can be used as design guidelines. Increasing the jitter percentage increases the curve respectively. Allowing the device to transmit faster over longer cable lengths. This relaxes the jitter tolerance of the system allowing more jitter into the system which could reduce the reliability and efficiency of the system. Alternatively, decreasing the jitter percentage

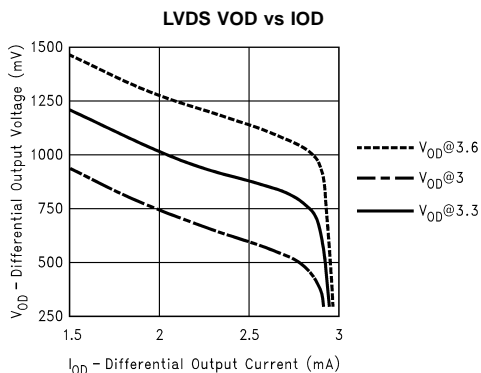

FIGURE 7. 3V DS90LV027 VOD vs IOD

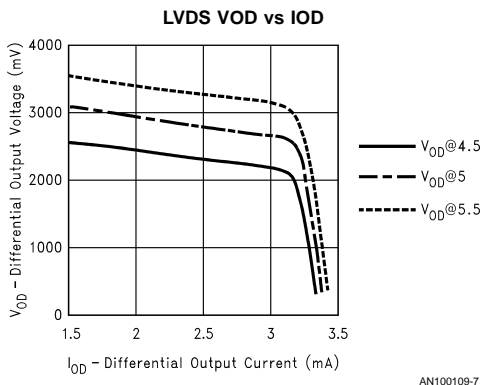

FIGURE 8. 5V DS90C031 VOD vs IOD

In addition to the AC analysis of jitter, a DC analysis was also completed. *Figure 7* and *Figure 8* shows the VOD vs IOD (Voltage Output Differential vs Current Output Differential) curve for the DS90LV027. This analysis is beneficial whenever the part is being operated at very low frequencies or DC. This may be the case for a control line or static line. This curve is generated by increasing the resistance and measuring voltage and current at the output of the device. The increasing resistance is used to model increasing cable length. Capacitance and inductance are being ignored since the part is operating at or near DC. The experiment was done across V_{CC} to show the impact of delta V_{CC} . The curve may be divided into two regions, the first where the curve is almost vertical and the second where the curve is near horizontal. The first region is where a large delta VOD results in a very small delta IOD. The second region is where a small delta VOD results in a very large delta IOD. Since the LVDS devices are current mode, with a constant output current, they should operate in the first region where current is more stable. Also, if the system will operate over the full power supply range then the lowest V_{CC} curve should be used to determine the operating range. For example in *Figure 7*, if a horizontal line is drawn at $VOD = 434$ mV and a vertical line is drawn at $IOD = 2.89$ mA, they will intersect the 3V V_{CC} curve at the intersection of the two regions. This point of intersection may be used to calculate a cable length. First, di-

vide VOD by IOD to obtain the maximum resistance. Second, when the resistance per unit (unit may be feet, meter, etc.) of the cable is divided into the maximum resistance, the result is the maximum cable length in units. For instance, $434 \text{ mV} \div 1.5 \text{ mA}$ results in a DC resistance of 150Ω . Assuming 100Ω for the termination load, 50Ω ($150\Omega - 100\Omega$) is left for the cable resistance. Since this is a differential device, 25Ω will be used for source side and 25Ω for the sink side. The cable used has $\approx 10\Omega/100$ meters. Therefore, the device should theoretically be able to drive 250 meters. Remember, this is a DC drive capability only. *Figure 8* shows a 5V VOD vs IOD curve for comparison. This curve was taken using the DS90C031. Notice that the higher V_{CC} level produces higher cable drive as expected. Recall, this is because the larger V_{CC} is capable of producing a larger VOD which allows the device to sustain a constant output current over longer cables.

To show this, *Figure 4* in AN-977 shows the same information as, except the data is for the DS90C031 using CAT 3 cable and was only taken up to 10 meters. Notice that the DS90C031 shows better performance over CAT 3 cable than the DS92LV027 in this report. The only difference is the DS90C031 is a 5V device versus a 3V device. To explain this, as the cable length is increased so does the resistance. Therefore, the VOD must increase in order to keep the current near constant. If VOD continues to increase, the output stage transistors go from operating in the saturation region to the linear region due to a decrease in drain to source voltage. This is why a 5V DS90C031 can drive over longer cable lengths than a 3V DS90LV027.

CONCLUSIONS

Eye patterns provide a useful tool to analyze jitter and thus the resulting signal quality as it captures the effects of a random data pattern. They provide a method to determine the maximum cable length for a given data rate or visa versa. However, different systems can tolerate amounts of jitter, commonly 5%, 10%, or 20% is selected, with 20% being the recommended maximum. Jitter in the system that is greater than 20% tends to close down the eye opening, and error free recovery of NRZ data becomes increasingly more difficult. This report shows typical performance of 3V LVDS devices across long CAT 3 cables. This data is intended to be used as a recommendation guideline for system designs. Importantly, system applications should always be evaluated individually and independently. Other parameters may limit cable length prior to the jitter. The operating region of the system should be determined by complete application and system parameters. It may be assumed that to operate below typical performance curves, given in this report are reliable and to operate beyond the curves is less reliable based on jitter alone.

Although operation up to 100 meters is obtainable with LVDS drivers, approximately 30 meters would be a recommended maximum cable distance. Beyond 30 meters dealing with other concerns like common mode will complicate system design. Is $\pm 1V$ common mode enough (application dependent) for reliable operation beyond 30 meters? Also the frequency roll off is steep beyond 30 meters. TIA/EIA-485-A may be a better choice for below 50 Mbps operation because of the $\pm 7V$ common mode and the 1000 meter cable drive capability of most 485 drivers.

For LVDS devices the power supply voltage plays a role in long cable application (above 10 meters). This is because the devices are current source devices. The higher V_{CC} , the longer the cable the device will be capable of driving.

REFERENCES

The following National Semiconductor Application Notes are recommended readings.

AN-808 Long Transmission Lines and Data Signal Quality

- AN-916 A Practical Guide to Cable Selection
- AN-1040 LVDS Performance: Bit Error Rate (BER) Testing Test Report #2
- AN-977 LVDS Signal Quality: Jitter Measurements Using Eye Patterns Test Report #1

LIFE SUPPORT POLICY

NATIONAL'S PRODUCTS ARE NOT AUTHORIZED FOR USE AS CRITICAL COMPONENTS IN LIFE SUPPORT DEVICES OR SYSTEMS WITHOUT THE EXPRESS WRITTEN APPROVAL OF THE PRESIDENT OF NATIONAL SEMICONDUCTOR CORPORATION. As used herein:

1. Life support devices or systems are devices or systems which, (a) are intended for surgical implant into the body, or (b) support or sustain life, and whose failure to perform when properly used in accordance with instructions for use provided in the labeling, can be reasonably expected to result in a significant injury to the user.
2. A critical component is any component of a life support device or system whose failure to perform can be reasonably expected to cause the failure of the life support device or system, or to affect its safety or effectiveness.

 **National Semiconductor Corporation**
Americas
Tel: 1-800-272-9959
Fax: 1-800-737-7018
Email: support@nsc.com

National Semiconductor Europe
Fax: +49 (0) 1 80-530 85 86
Email: europe.support@nsc.com
Deutsch Tel: +49 (0) 1 80-530 85 85
English Tel: +49 (0) 1 80-532 78 32
Français Tel: +49 (0) 1 80-532 93 58
Italiano Tel: +49 (0) 1 80-534 16 80

National Semiconductor Asia Pacific Customer Response Group
Tel: 65-2544466
Fax: 65-2504466
Email: sea.support@nsc.com

National Semiconductor Japan Ltd.
Tel: 81-3-5639-7560
Fax: 81-3-5639-7507

www.national.com

IMPORTANT NOTICE

Texas Instruments Incorporated and its subsidiaries (TI) reserve the right to make corrections, modifications, enhancements, improvements, and other changes to its products and services at any time and to discontinue any product or service without notice. Customers should obtain the latest relevant information before placing orders and should verify that such information is current and complete. All products are sold subject to TI's terms and conditions of sale supplied at the time of order acknowledgment.

TI warrants performance of its hardware products to the specifications applicable at the time of sale in accordance with TI's standard warranty. Testing and other quality control techniques are used to the extent TI deems necessary to support this warranty. Except where mandated by government requirements, testing of all parameters of each product is not necessarily performed.

TI assumes no liability for applications assistance or customer product design. Customers are responsible for their products and applications using TI components. To minimize the risks associated with customer products and applications, customers should provide adequate design and operating safeguards.

TI does not warrant or represent that any license, either express or implied, is granted under any TI patent right, copyright, mask work right, or other TI intellectual property right relating to any combination, machine, or process in which TI products or services are used. Information published by TI regarding third-party products or services does not constitute a license from TI to use such products or services or a warranty or endorsement thereof. Use of such information may require a license from a third party under the patents or other intellectual property of the third party, or a license from TI under the patents or other intellectual property of TI.

Reproduction of TI information in TI data books or data sheets is permissible only if reproduction is without alteration and is accompanied by all associated warranties, conditions, limitations, and notices. Reproduction of this information with alteration is an unfair and deceptive business practice. TI is not responsible or liable for such altered documentation. Information of third parties may be subject to additional restrictions.

Resale of TI products or services with statements different from or beyond the parameters stated by TI for that product or service voids all express and any implied warranties for the associated TI product or service and is an unfair and deceptive business practice. TI is not responsible or liable for any such statements.

TI products are not authorized for use in safety-critical applications (such as life support) where a failure of the TI product would reasonably be expected to cause severe personal injury or death, unless officers of the parties have executed an agreement specifically governing such use. Buyers represent that they have all necessary expertise in the safety and regulatory ramifications of their applications, and acknowledge and agree that they are solely responsible for all legal, regulatory and safety-related requirements concerning their products and any use of TI products in such safety-critical applications, notwithstanding any applications-related information or support that may be provided by TI. Further, Buyers must fully indemnify TI and its representatives against any damages arising out of the use of TI products in such safety-critical applications.

TI products are neither designed nor intended for use in military/aerospace applications or environments unless the TI products are specifically designated by TI as military-grade or "enhanced plastic." Only products designated by TI as military-grade meet military specifications. Buyers acknowledge and agree that any such use of TI products which TI has not designated as military-grade is solely at the Buyer's risk, and that they are solely responsible for compliance with all legal and regulatory requirements in connection with such use.

TI products are neither designed nor intended for use in automotive applications or environments unless the specific TI products are designated by TI as compliant with ISO/TS 16949 requirements. Buyers acknowledge and agree that, if they use any non-designated products in automotive applications, TI will not be responsible for any failure to meet such requirements.

Following are URLs where you can obtain information on other Texas Instruments products and application solutions:

Products

Audio	www.ti.com/audio
Amplifiers	amplifier.ti.com
Data Converters	dataconverter.ti.com
DLP® Products	www.dlp.com
DSP	dsp.ti.com
Clocks and Timers	www.ti.com/clocks
Interface	interface.ti.com
Logic	logic.ti.com
Power Mgmt	power.ti.com
Microcontrollers	microcontroller.ti.com
RFID	www.ti-rfid.com
OMAP Mobile Processors	www.ti.com/omap
Wireless Connectivity	www.ti.com/wirelessconnectivity

Applications

Communications and Telecom	www.ti.com/communications
Computers and Peripherals	www.ti.com/computers
Consumer Electronics	www.ti.com/consumer-apps
Energy and Lighting	www.ti.com/energy
Industrial	www.ti.com/industrial
Medical	www.ti.com/medical
Security	www.ti.com/security
Space, Avionics and Defense	www.ti.com/space-avionics-defense
Transportation and Automotive	www.ti.com/automotive
Video and Imaging	www.ti.com/video

TI E2E Community Home Page

e2e.ti.com

Mailing Address: Texas Instruments, Post Office Box 655303, Dallas, Texas 75265
Copyright © 2011, Texas Instruments Incorporated