

APPROVAL NO.	ELECTRIC DOUBLE LAYER CAPACITOR <i>PRO-CAP</i>	PAGE : 1 of 6
		DATE :

ELECTRIC DOUBLE LAYER CAPACITOR

PRO-CAP

APPROVAL DRAWING

CATALOGE TYPE : SEC5R5V474Z

APPROVAL SEAL

**These products are developed based on our spec.
because you have not submitted your spec. about
these items.**

APPROVAL NO.	ELECTRIC DOUBLE LAYER CAPACITOR PRO-CAP	PAGE : 2 of 6
		DATE :

1. Scope

This specification applies to the electric double layer capacitor (PRO-CAP), SEC series.

2. Typical Characteristics

No	ITEM	Performance
1	Rating Voltage / Maximum Surge Voltage	5.5V / 6.3V
2	Operating Temperature Range	-25°C ~ +70°C
3	Capacitance Tolerance	-20% ~ +80%

3. Characteristics

No	ITEM		Performance	Test Method	
1	Initial Characteristics	Capacitance	0.47F(0.38 ~0.84F)	5.0V→2.0V, 1mA CC discharge, $C=I*(T_2-T_1)/(V_1-V_2)$	
		Leakage Current(LC)	Less than 315μA	5.0V 30min, $I=V_1/R[A]$	
		Internal resistance	Less than 30Ω	at 1kHz	
		Self discharge	More than 4.00V	It was kept voltage 24hr later after applied 5.0V for 1hr	
2	Life (High Temperature loading)	Capacitance change	≤ ±30 % of initial measured value	Test temperature : 70±2°C Test time : 1000(+48, -0) hours Applied voltage : the rated W.V.(5.5V.DC) It was kept voltage 100hr later after applied 5.0V for 1hr	
		Leakage Current(LC)	≤ 2 times of initial specified value		
		Internal resistance	≤ 4 times of initial specified value		
		Self discharge	More than 3.6V		
3	Storage Life (Shelf life Characteristics)	Capacitance	≤ ±30 % of initial measured value	Test temperature : 70±2°C Test time : 1000(+48, -0) hours Note : no voltage applied	
		Leakage Current(LC)	≤ 2 times of initial specified value		
		Internal resistance	≤ 4 times of initial specified value		
4	Humidity (Moisture resistance)	Capacitance	≤ ±30 % of initial measured value	Test temperature : 55±2°C Relative humidity : 90 to 95%RH Test time : 500(+24, -0) hours Applied voltage : no voltage applied	
		Leakage Current(LC)	≤ 2 times of initial specified value		
		Internal resistance	≤ 4 times of initial specified value		
5	Temperature Characteristics	step 2	Capacitance change	≤ ±50 % of initial measured value	The capacitor under test shall be stabilize in regard to temperature, at the temperature of 5 steps, in order, given in the under table. Electrical characteristics shall be measured at each temperature after 1 hour interval. Because the temperature of the capacitor can be stabilized. Step 1 : + 25°C Step 2 : - 25°C Step 3 : + 25°C Step 4 : + 70°C Step 5 : + 25°C
			Internal resistance	≤ 4 times of initial specified value	
		step 4	Capacitance change	≤ ±20 % of initial measured value	
			Leakage Current(LC)	≤ 4 times of initial specified value	
		step 5	Internal resistance	Initial internal resistance value or less	
			Capacitance change	≤ ±20 % of initial measured value	
Leakage Current(LC)	initial specified value or less				
6	Vibration	Capacitance	≤ ±10 % of initial measured value	Frequency range : 10 ~ 55Hz amplitude : 1.5mm(total excursion) Immersion time : 2 hours each 3 mutually perpendicular direction (a total of 6 hours)	
		Leakage Current(LC)	initial specified value or less		
		Internal resistance	initial specified value or less		
		Appearance	no break		
7	Resistance to soldering heat	Capacitance	≤ ±10 % of initial measured value	Immersion depth : 2 to 2.5mm from the root of terminal Solder temperature : 260 ±5°C Immersion time : 10±1 seconds	
		Leakage Current(LC)	initial specified value or less		
		Internal resistance	initial specified value or less		
		Appearance	no break		
8	Surge voltage	Capacitance	≤ ±10 % of initial measured value	Surge voltage : 6.3V , temperature : 70 ±2°C Number of cycle : 1,000 cycles Charge time : 30sec(resistance 10Ω) Discharge time : 570sec(no resistance)	
		Leakage Current(LC)	initial specified value or less		
		Internal resistance	initial specified value or less		
9	Charge & discharge cycle	Capacitance	≤ ±30 % of initial measured value	Applied voltage : 5.5V , temperature : room temp. Number of cycle : 15,000 cycles Charge time : 30sec(resistance 10Ω) Discharge time : 30sec(no resistance)	
		Leakage Current(LC)	≤ 2 times of initial specified value		
		Internal resistance	≤ 4 times of initial specified value		
10	Solderability	Appearance	shall cover more 75% of lead surface.	Immersion depth : 2 to 2.5mm from the root of terminal Solder temperature : 230±5°C Immersion time : 2.0±0.5 sec.	
11	Lead(terminal) strength	Appearance	no break	Pull test, 0.51kgf for 10sec	

4. Dimensions[mm]

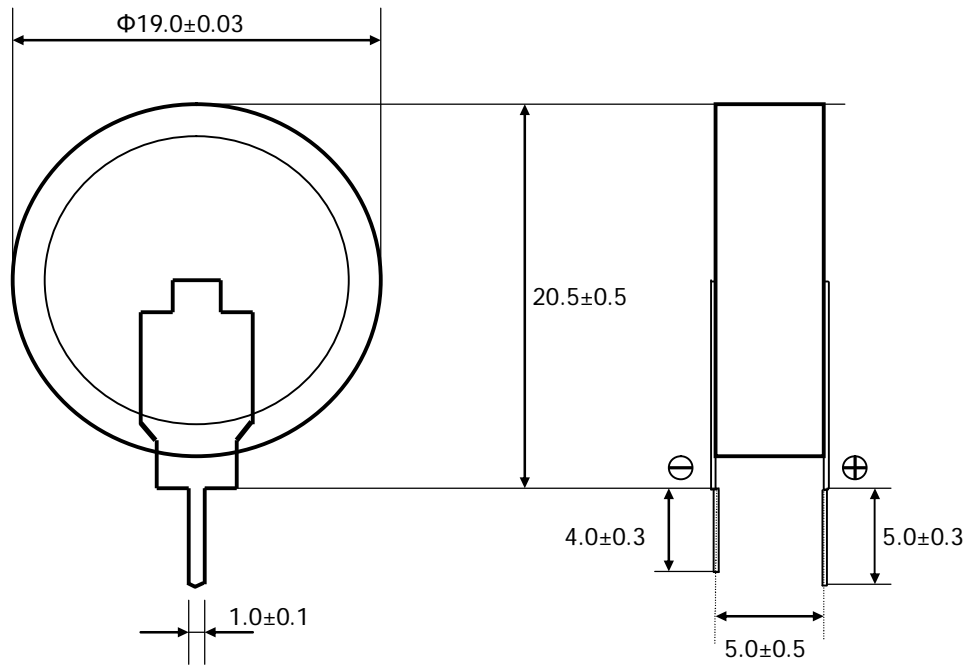

5. Marking(The item is marked on vinyl sleeve continuously by printing)

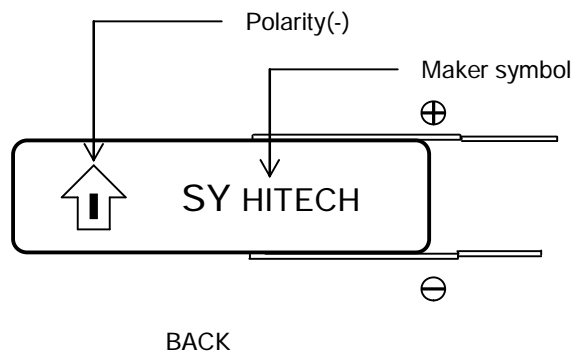
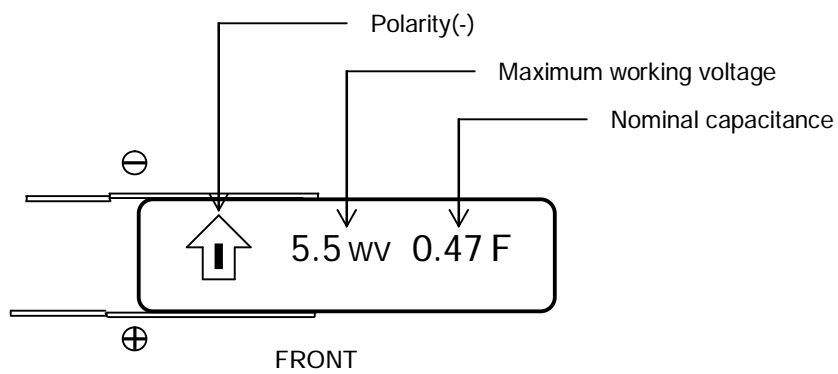

6. Packing

Type		Quantity(pcs)			Size(W × H × T mm)	
		Vinyl Bag	Inlet Box	Outlet Box	Inlet Box	Outlet Box
5.5V-0.47F	Bulk	100	500	3,000	280 × 280 × 60	300 × 300 × 280

7. Part number system

S E C 5 R 5 V 4 7 4 Z





Capacitance Tolerance

Tolerance	Symbol	Outlet Box	Symbol
-10%~40%	K	-20%~+20%	M
0%~+100%	P	-30%~+30%	N
-10%~+50%	T	-10%~+30%	Q
-10%~+100%	W	-10%~20%	V
-20%~+80%	Z		

Nominal Capacitance

Capacitance	Symbol	Capacitance	Symbol
2.0F	205	0.47F	474
1.0F	105	-0.1F	104

Lead Type

Form				
Symbol	M	H	V	O

Rated Voltage

Rated Voltage	2.5V	5.5V	6.3V
Symbol	2R5	5R5	6R3

Series Name

Series	Symbol
Standard	SEC
High temperature	TEC
High working voltage	VEC
Long life	LEC
Mono cell	MEC

8. Measuring method

Capacitance

Capacitance shall be calculated from the equation below.

Capacitance shall be measured during discharge cycle. Because PRO-CAP's are applied electric equipment's by discharging it's electric current.

Charge the EDLC 30 minutes with 5 voltage by constant voltage power supply. And then measure the time(T) which the voltage between terminal is reaching from 5V into 2V. Discharging current is 1mA.

$C = (I \times T) / \Delta V$ C : Capacitance[F] I : Discharge current[A]

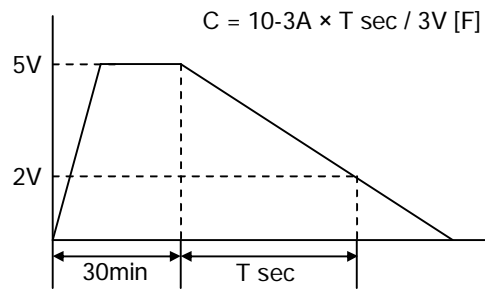
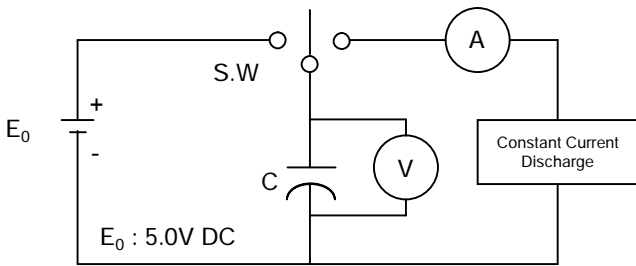

Equivalent Series Resistance

ESR shall be calculated from the equation below.

Prior to measurement, both lead terminals must be short-circuited for a minimum of 30 minutes.

The lead terminal connected to the metal can case is connected to the negative side of the power supply.

Apply the EDLC with 1mA current at 1KHz. And then measure the voltage between the terminal.

$R = V \times 10^3$ R : Internal resistance[Ω] V : Measured voltage between the terminal[V]

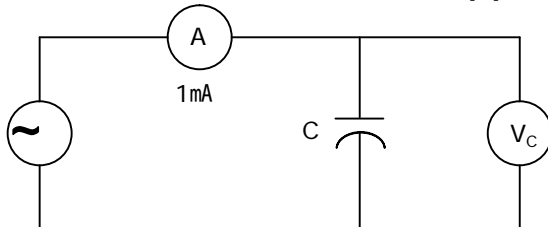

$ESR = V_C / 10^{-3} [\Omega]$

Leakage Current (at 30 minutes charging)

Leakage Current shall be calculated from the equation below.

Prior to measurement, both lead terminals must be short-circuited for a minimum of 30 minutes. The lead terminal connected to the metal can case is connected to the negative side of the power supply.

Apply the EDLC 5V in 30 minutes and then measure the voltage.

$LC = V/R$ LC : Leakage Current[A] V : Measured Voltage[V] R : Resistance(99Ω)[Ω]

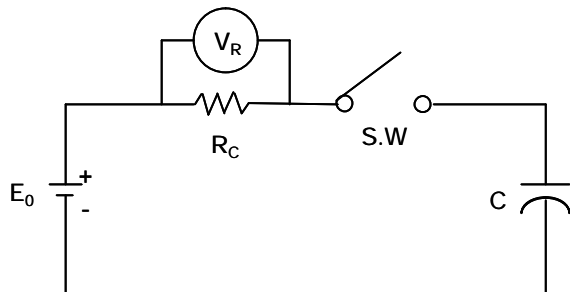

$LC = (V_R / R_C) \times 10^3 [mA]$

$E_0 : 5.0V DC$
 R_C : See the right table

Capacitance	R_C
~ 0.047F	1000Ω
0.1F ~ 0.47F	100Ω
1.0F	10Ω

APPROVAL NO.	ELECTRIC DOUBLE LAYER CAPACITOR PRO-CAP	PAGE : 5 of 6
		DATE :

9. Application guidelines

9.1 Voltage

If a PRO-CAP is used at a voltage exceeding its rated voltage, not only is its life time shortened, but depending on the actual voltage, gas generated by electrochemical reactions inside the capacitor may cause it to leak or rupture.

9.2 Polarity

Be sure to verify the polarity of the capacitor before use. If a reverse voltage is applied for a long time, capacitor lifetime is shortened and serious damage such as electrolyte leakage may occur. Further more, there may be leftover electric charge from capacitor testing that low-withstanding voltage parts of semiconductors, etc.

9.3 Ambient Temperature

- (1) Capacitor life is affected by operating temperature. In general, lowering ambient temperature by 10°C will double the life of a capacitor. Use the capacitor at the lowest possible temperature under the maximum guaranteed temperature.
- (2) Operation above the maximum specified temperature not only shortens capacitor life, but can also cause serious damage such as electrolyte leakage. Verify the operating temperature of the capacitor by taking into consideration not only the ambient temperature and temperature inside the unit, but also the radiation from heat generating elements inside the unit (power transistors, IC's, resistors, etc) and self-heating due to ripple current. Be careful not to place heat-generating elements across from the capacitor on the opposite of the PCB.

9.4 Voltage Drop During Backup Operation

Take careful notice of the voltage drop caused by the instantaneous operating current and the internal resistance of the PRO-CAP during the switch from power-failure-detection to backup mode. Because internal resistance varies by product, use the following table to decide the correct operating (discharge) current.

9.5 Ripple Current

PRO-CAP have a higher internal resistance than do electrolytic capacitors and are more susceptible to internal heat generation when exposed to ripple current. When the temperature of the element rises, a reacting current flows inside the PRO-CAP, generating reaction products and raising internal resistance even further. This makes it difficult to maintain capacitance. Set the allowable limit for the ripple current-induced rise in capacitor temperature to 3°C measured at the surface of the capacitor.

9.6 Connection Capacitors in Series

Taking into consideration the possibility of an imbalance in the voltages across the capacitors, make sure that the voltage applied to each capacitor will not exceed the rated voltage. If the voltage balance breaks down, an overvoltage condition could result. To prevent this from occurring, add a voltage-dividing resistor in parallel with each capacitor, allowing for the capacitor's leakage current.

9.7 Heat Stress During Soldering

Excessive heat stress may result in the deterioration of the electrical characteristics of the capacitor, loss of air-tightness, and electrolyte leakage due to the rise in internal pressure.

- (1) If the tip of the soldering iron touches the capacitor's external sleeve, the sleeve will melt or break.
- (2) Use the general reference chart below to set soldering temperature and time.
- (3) When soldering with a soldering iron, do not touch the tip to the body of the capacitor.
Minimize the time that the soldering iron is in contact with the capacitor terminals.
- (4) When using equipment such as a UV curing oven for pre-heating and adhesive hardening, do not set the temperature above 150°C. If the temperature is higher than this, the external sleeve may crack and the end seal may suffer reduced performance.
- (5) Never perform reflow soldering on PRO-CAP using infrared heating or atmospheric heating methods.

9.8 Circuit Board Cleaning

Circuit boards can be immersed or ultrasonically cleaned using suitable cleaning solvents for up to 5 minutes and up to 60°C maximum temperature. The boards should be thoroughly rinsed and dried.

Recommended cleaning solvent include.

Pine Alpha ST-100S, Sunelec B-12, DK beclear CW-5790, Aqua cleaner 210SEP, Cold Cleaner P3-375, Telpen Cleaner EC-7R, Clean-thru 750H, Clean-thru 750L, Clean-thru 710M, Techno Cleaner 219, Techno Care FRV-1

* Consult with us if you are using a solvent other than any of those listed above.

* The use of ozone depleting cleaning agents are not recommended in the interest of protecting the environment.