

Embest Mini8100 Processor Card



General Description

Embest Mini8100 processor card is designed specially to be the heart of your next embedded design. The tiny board integrates TI OMAP3530 processor (ARM Cortex-A8 Core ~600MHz paired with a TMS320C64x+ DSP ~430MHz). The processor card takes use of all common features of OMAP3530 and the connection between the processor card and your carrierboard is through two 1.27mm space 90-pin biserial dip connectors. 16-bit data bus, I/O and all other hardware interfaces are all expanded via these two connectors. The fully expansion can be used adapted to customer requirements.

Integration of the Embest Mini8100 processor card to customer special design is fully supported by Embest technologies. Embest also designed an expansion board which can fully evaluate Mini8100. The whole system is called [SBC8100](#). Embest offers Linux 2.6.22 and WinCE6.0 BSP for this board. Customers can leverage our experience to increase your own productivity. The optimal embedded microprocessor solution provides users with a flexible development environment based on OMAP3530 and a shortened development timeframe.

Layout and Functional Block Diagram

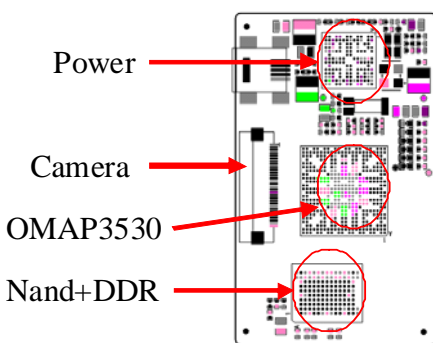

Embest Mini8100 Layout

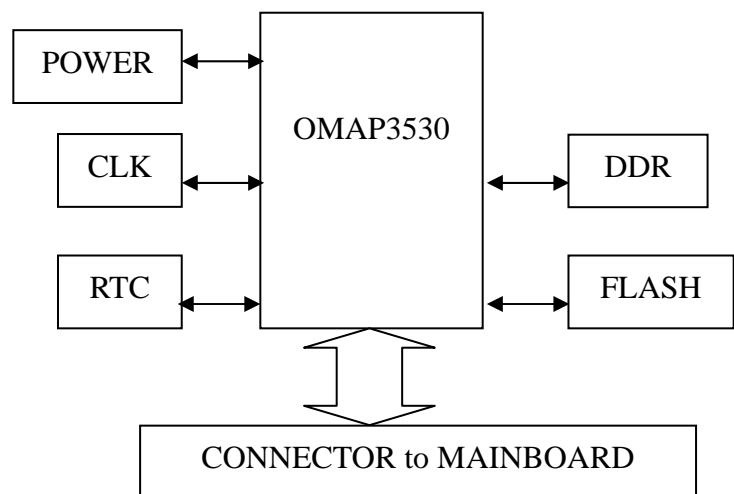

Embest Mini8100 Functional Block Diagram

Dimensions

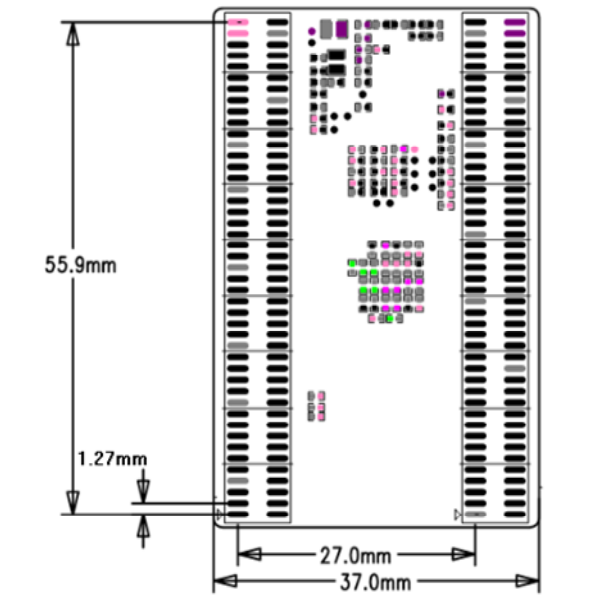

Camera interface

Embest Mini8100 processor card uses a 30-pin FPC connector, supporting analog camera. Detailed pin explanation is as following:

Pin	Name	Function explanation
1	GND	GND
2	D0	Digital image data bit 0
3	D1	Digital image data bit 1
4	D2	Digital image data bit 2
5	D3	Digital image data bit 3
6	D4	Digital image data bit 4
7	D5	Digital image data bit 5
8	D6	Digital image data bit 6
9	D7	Digital image data bit 7
10	D8	Digital image data bit 8
11	D9	Digital image data bit 9
12	D10	Digital image data bit 10
13	D11	Digital image data bit 11
14	GND	GND
15	PCLK	Pixel clock
16	GND	GND
17	HS	Horizontal synchronization
18	VDD50	5V

19	VS	Vertical synchronization
20	VDD33	3.3V
21	XCLKA	Clock output a
22	XCLKB	Clock output b
23	GND	GND
24	FLD	Field identification
25	WEN	Write Enable
26	STROBE	Flash strobe control signal
27	SDA	IIC2 master serial clock
28	SCL	IIC2 serial bidirectional data
29	GND	GND
30	VDD18	1.8V

90-pin connecter

Embest Mini8100 processor card is connected to carrierboard via two 1.27mm space 90-pin biserial dip connectors.

Detailed pin explanation for CON1 is as following:

Pin	Name	Type	Function explanation
1	G_NWE	O	GPMC Write Enable
2	G_NOE	O	GPMC Read Enable
3	G_NCS7GPT8G_DIR	OIOO	GPMC Chip Select bit 7PWM or event for GP timer 8GPMC IO direction control for use with external transceivers
4	G_NCS4GPT9DMAREQ1	OIOI	GPMC Chip Select bit 7PWM or event for GP timer 9External DMA request 1
5	G_NCS6GPT11DMAREQ3	OIOI	GPMC Chip Select bit 7PWM or event for GP timer 11 External DMA request 3
6	G_NCS3DMAREQ0	OI	GPMC Chip Select bit 7External DMA request 0
7	GND	GND	GND
8	G_WAIT0	I	External indication of wait
9	G_NBE0 / G_CLE	O	Lower Byte Enable. Also used for Command Latch Enable
10	G_NATV_ALE	O	Address Valid or Address Latch Enable
11	G_NBE1	O	Upper Byte Enable
12	HDQ_SIO	IOD	Bidirectional HDQ 1-Wire control and data
13	MMC1_D0	IO	MMC/SD Card Data bit 0
14	MMC1_D1	IO	MMC/SD Card Data bit 1
15	MMC1_D2	IO	MMC/SD Card Data bit 2
16	MMC1_D6/IO128	IO	MMC/SD Card Data bit 6
17	MMC1_D5/IO127	IO	MMC/SD Card Data bit 5
18	MMC1_D4/IO126	IO	MMC/SD Card Data bit 4
19	MMC1_D7/IO129	IO	MMC/SD Card Data bit 7

20	MMC1_D3	IO	MMC/SD Card Data bit 3
21	GND	GND	GND
22	MMC1_CLK	O	MMC/SD Output Clock
23	MMC1_CMD	IO	MMC/SD command signal
24	VMMC1	P	Power supply for SD/MMC1 (3.0 / 1.8V)
25	UART3_RX_IRRX	I	UART3 Receive data, IR and Remote RX
26	UART3_CTS_RCTX	IO	UART3 Clear To Send, Remote TX
27	UART3_TX_IRTX	O	UART3 Transmit data, IR TX
28	UART3_RTS_SD	O	UART3 Request To Send, IR enable
29	DSS_ACBIAS	O	AC bias control (STN) or pixel data enable (TFT) output
30	DSS_VSYNC	O	LCD Vertical Synchronization
31	GND	GND	GND
32	DSS_HSYNC	O	LCD Horizontal Synchronization
33	DSS_CLK	O	LCD Pixel Clock
34	DSS_D6	IO	LCD Pixel Data bit 6
35	DSS_D8	IO	LCD Pixel Data bit 8
36	DSS_D7	IO	LCD Pixel Data bit 7
37	DSS_D9	IO	LCD Pixel Data bit 9
38	DSS_D20	IO	LCD Pixel Data bit 20
39	DSS_D17	IO	LCD Pixel Data bit 17
40	DSS_D16	IO	LCD Pixel Data bit 16
41	DSS_D18	IO	LCD Pixel Data bit 18
42	DSS_D10	IO	LCD Pixel Data bit 10
43	DSS_D5	IO	LCD Pixel Data bit 5
44	DSS_D4	IO	LCD Pixel Data bit 4
45	GND	GND	GND
46	DSS_D2	IO	LCD Pixel Data bit 2
47	DSS_D3	IO	LCD Pixel Data bit 3
48	DSS_D0	IO	LCD Pixel Data bit 0
49	DSS_D15	IO	LCD Pixel Data bit 15
50	DSS_D11	IO	LCD Pixel Data bit 11
51	DSS_D23	IO	LCD Pixel Data bit 23
52	DSS_D22	IO	LCD Pixel Data bit 22
53	DSS_D14	IO	LCD Pixel Data bit 14
54	DSS_D19	IO	LCD Pixel Data bit 19
55	DSS_D13	IO	LCD Pixel Data bit 13
56	DSS_D21	IO	LCD Pixel Data bit 21
57	DSS_D1	IO	LCD Pixel Data bit 1
58	DSS_D12	IO	LCD Pixel Data bit 12
59	GND	GND	GND
60	MCBSP1_FSR/IO157	IO	Receive frame synchronization
61	MCBSP1_CLKR/IO156	IO	Receive Clock

62	MCBSP1_FSX/IO161	IO	Transmit frame synchronization
63	MCBSP1_CLKS/IO160	I	External clock input
64	MCBSP1_CLKX/IO162	IO	Transmit clock
65	MCBSP1_DR/IO159	I	Received serial data
66	MCBSP1_DX/IO158	IO	Transmitted serial data
67	GND	GND	GND
68	TV_OUTC	O	TV analog output S-VIDEO: TV_OUT2
69	TV_OUTY	O	TV analog output Composite: TV_OUT1
70	VDD33	P	Power supply for camera (3.3V 500mA)
71	IIC3_SCL	IODU	I2C Master Serial clock. Output is open drain
72	IIC3_SDA	IODU	I2C Serial Bidirectional Data. Output is open drain
73	IO25	IO	General-purpose IO 183
74	IO27	IO	General-purpose IO 183
75	BOOTJUMP	I	Boot configuration mode bit 5.
76	GND	GND	GND
77	VBUS	P	VBUS power rail (5V 10mA)
78	USB_DN	IO	USB Data N
79	USB_ID	I	USB ID
80	USB_DP	IO	USB Data P
81	PWM0	O	Pulse width driver 0
82	KR0	I	Keypad row 0
83	KR1	I	Keypad row 1
84	KR2	I	Keypad row 2
85	KR3	I	Keypad row 3
86	KR4	I	Keypad row 4
87	VDD18	P	Power supply from TPS65930 (VIO 1.8V)
88	GND	GND	GND
89	VDD18	P	Power supply from TPS65930 (VIO 1.8V)
90	BKBAT	P	Backup battery

Detailed pin explanation for CON2 is as following:

Pin	Name	Type	Function explanation
1	GND	GND	GND
2	G_D14	IO	GPMC data bit 14
3	G_D13	IO	GPMC data bit 13
4	G_D10	IO	GPMC data bit 10
5	G_D8	IO	GPMC data bit 8
6	G_D9	IO	GPMC data bit 9
7	G_D5	IO	GPMC data bit 5
8	G_D7	IO	GPMC data bit 7

9	G_D3	IO	GPMC data bit 3
10	G_D6	IO	GPMC data bit 6
11	G_D12	IO	GPMC data bit 12
12	G_D2	IO	GPMC data bit 2
13	G_D11	IO	GPMC data bit 11
14	G_D1	IO	GPMC data bit 1
15	G_D4	IO	GPMC data bit 4
16	G_D0	IO	GPMC data bit 0
17	G_A2	O	GPMC address bit 2
18	G_A3	O	GPMC address bit 3
19	G_A1	O	GPMC address bit 1
20	G_A6	O	GPMC address bit 6
21	G_A4	O	GPMC address bit 4
22	G_A7	O	GPMC address bit 7
23	G_A5	O	GPMC address bit 5
24	G_A8	O	GPMC address bit 8
25	G_A9	O	GPMC address bit 9
26	G_D15	IO	GPMC data bit 15
27	G_A10	O	GPMC address bit 10
28	GND	GND	GND
29	SPI2_CS1 GPT8	OIO	SPI Enable 1PWM or event for GP timer 8
30	SPI2_CS10 GPT11	IOIO	SPI Enable 0PWM or event for GP timer 11
31	SPI2_SIMO GPT9	IOIO	Slave data in, master data out PWM or event for GP timer 9
32	SPI2_CLK	IO	SPI Clock
33	SPI2_SOMI GPT10	IOIO	Slave data out, master data in PWM or event for GP timer 10
34	SPI1_CS3	O	SPI Enable 3
35	SPI1_CS0	IO	SPI Enable 0
36	SPI1_SIMO	IO	Slave data in, master data out
37	SPI1_SOMI	IO	Slave data out, master data in
38	SPI1_CLK	IO	SPI Clock
39	GND	GND	GND
40	GPIO0	IO	GPIO0 /card detection 1
41	MMC2_D2 SPI3_CS1	IOO	MMC/SD Card Data bit 2SPI Enable 1
42	MMC2_D3SPI3_CS0	IOIO	MMC/SD Card Data bit 3SPI Enable 0
43	MMC2_D0SPI3_SOMI	IOIO	MMC/SD Card Data bit 0Slave data out, master data in
44	MMC2_D1	IO	MMC/SD Card Data bit 1
45	MMC2_CMDSPI3_SIMO	IOIO	MMC/SD command signalSlave data in, master data out
46	MMC2_CLKSPI3_CLK	OIO	MMC/SD Output ClockSPI Clock

47	BSP3_DRUART2_RTS	IO	Received serial dataUART2 Request To Send
48	BSP3_CLKUART2_TX	IOO	Combined serial clockUART2 Transmit data
49	BSP3_FSXUART2_RX	IOI	Combined frame synchronizationUART2 Receive data
50	BSP3_DXUART2_CTS	IOI	Transmitted serial dataUART2 Clear To Send
51	GND	GND	GND
52	UART1_CTS	I	UART1 Clear To Send
53	UART1_TX	O	UART1 Transmit data
54	UART1_RX	I	UART1 Receive data
55	UART1_RTS	O	UART1 Request To Send
56	USB1HS_STP	O	Dedicated for external transceiver Stop signal
57	USB1HS_D3	IO	Dedicated for external transceiver Bidirectional data bus
58	USB1HS_D5	IO	Dedicated for external transceiver Bidirectional data bus
59	USB1HS_6	IO	Dedicated for external transceiver Bidirectional data bus
60	USB1HS_D7	IO	Dedicated for external transceiver Bidirectional data bus
61	USB1HS_D1	IO	Dedicated for external transceiver Bidirectional data bus
62	USB1HS_D2	IO	Dedicated for external transceiver Bidirectional data bus
63	USB1HS_D4	IO	Dedicated for external transceiver Bidirectional data bus
64	USB1HS_D0	IO	Dedicated for external transceiver Bidirectional data bus
65	USB1HS_NXT	I	Dedicated for external transceiver Next signal from PHY
66	USB1HS_CLK	O	Dedicated for external transceiver 60-MHz clock
67	GND	GND	GND
68	USB1HS_DIR	I	Dedicated for external transceiver data form PHY
69	SYS_CLKOUT1	O	Configurable output clock1
70	LEDA	OD	LED leg A
71	LEDB	OD	LED leg B
72	ADCIN0	AI	ADC input0 (Battery type)
73	NRESPWRON	I	Power On Reset
74	NRESWARM	IOD U	Warm Boot Reset (open drain output)
75	SYSEN	ODU	System enable output
76	GND	GND	GND

77	REGEN	ODU	Enable signal for external LDO
78	ADCIN1	AI	ADC input1 (General-purpose ADC input)
79	KC0	OD	Keypad column 0
80	KC1	OD	Keypad column 0
81	KC2	OD	Keypad column 0
82	KC3	OD	Keypad column 0
83	AUDIO_IN	AI	Analog microphone bias 1
84	AUDIO_OR	AO	Predriver output right P for external class-D amplifier
85	AUXR	AI	Auxiliary audio input right
86	AUDIO_OL	AO	Predriver output left P for external class-D amplifier
87	GND	GND	GND
88	VBAT	P	Power supply (3V - 4.2V 1.5A)
89	ON/OFF	I	Input; detect a control command to start or stop the system
90	VBAT	P	Power supply (3V - 4.2V 1.5A)

Order Information

Order No.	T400142
Item	Embest Mini8100 Processor Card
Software and Documents	Embest offers SBC8100 CD data if you buy Mini8100.
Price	Please contact Embest



Embest Info&Tech Co., LTD.

Room 509, Luohu Science&Technology Building,
 #85 Taining Rd., Shenzhen, Guangdong, China 518020

Tel: +86-755-25635656/25636285

Fax: +86-755-25616057

Email: market@embedinfo.com

<http://www.embedinfo.com/english>

<http://www.armkits.com>